



PLANO DIRETOR DE PORTO ALEGRE

QUEM AMA A CIDADE
PLANEJA O FUTURO COM ELA

1º SEMINÁRIO



**EVOLUÇÃO URBANA | PLANOS
PLANEJAMENTO / DESENHO**

**MOTIVAÇÃO
ORIGEM DO URBANISMO**

**DESAFIOS / OPORTUNIDADES
HABITAR**

HABITAR A CIDADE | REGRAS

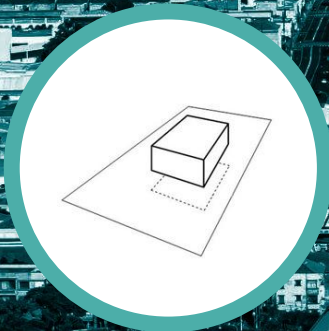

TAXAS DE
OCUPAÇÃO

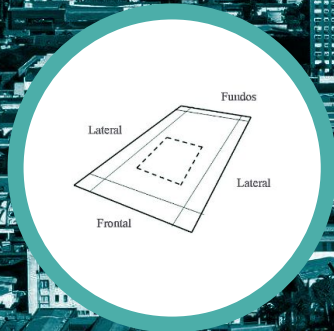

RECUOS

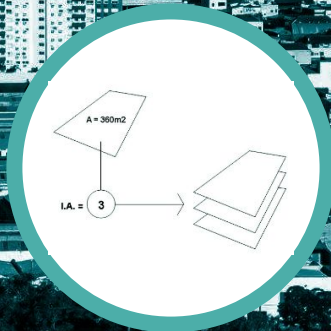

ÍNDICES DE
APROVEITAMENTO



ALTURAS



DENSIDADES

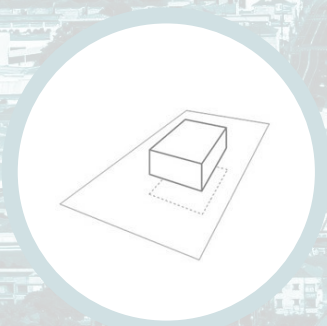

TAXAS DE OCUPAÇÃO

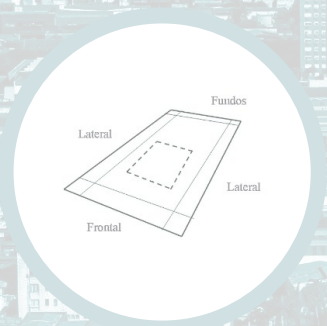

RECUOS

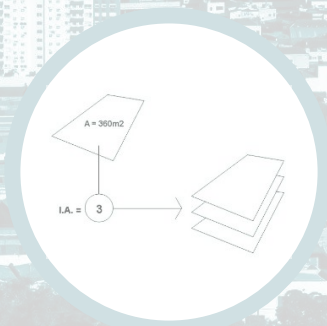

ÍNDICES DE APROVEITAMENTO

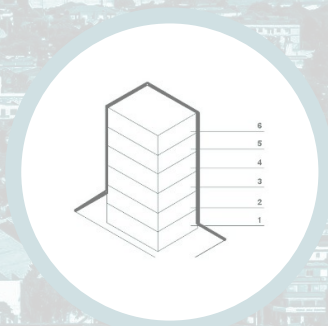

ALTURAS



DENSIDADES



URWIN, 1909.

17 ECON/HA



Diagrams
HENRIQUE, 2019.



URWIN, 1909.



Gustave Dore, London
(1872).

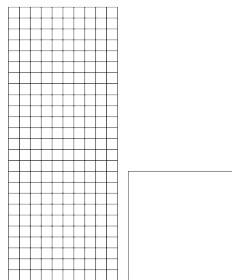

JACOBS, 1961.

The Death and Life of
Great American Cities
(1961).





URWIN, 1909.

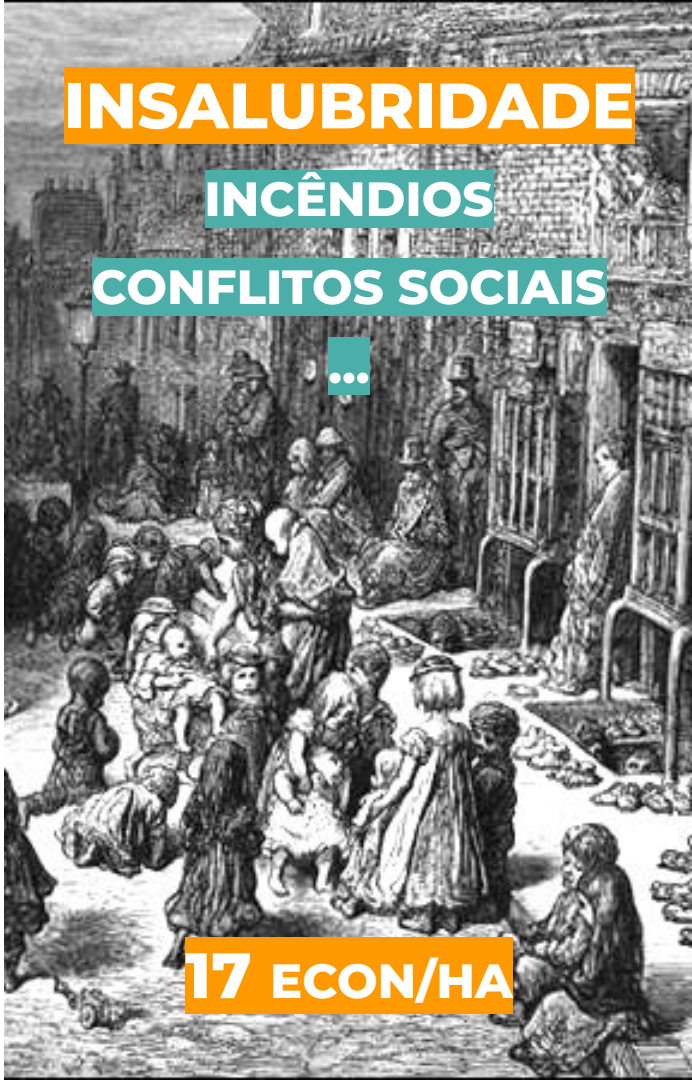

INSALUBRIDADE

INCÊNDIOS

CONFLITOS SOCIAIS



17 ECON/HA

Gustave Dore, London
(1872).

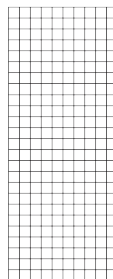

JACOBS, 1961.



VITALIDADE

TRANSPORTE

INFRAESTRUTURAS



250 ECON/HA

The Death and Life of
Great American Cities
(1961).

HABITAR A CIDADE | REGRAS

econômica



cultural



ambiental

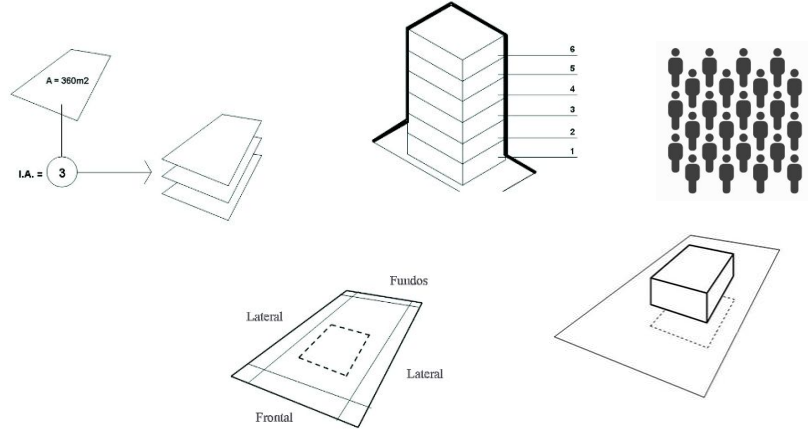

social



“Acreditamos firmemente que **o campo do desenho (urbano) não deve simplesmente aderir a esses padrões como um contexto existente de forma neutra**, mas deve se envolver **ativamente em discuti-los para torná-los sujeitos ao desenho também.**”

Lehnerer (2009)

HABITAR A CIDADE | INDICADORES

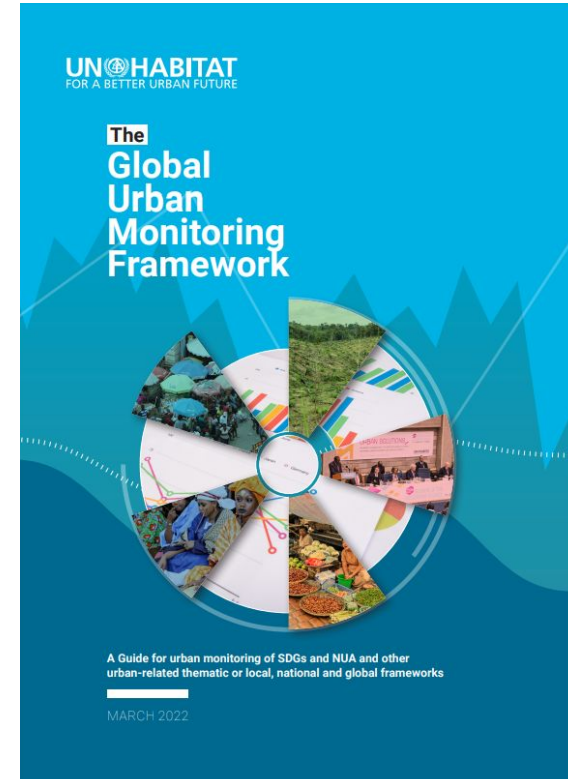
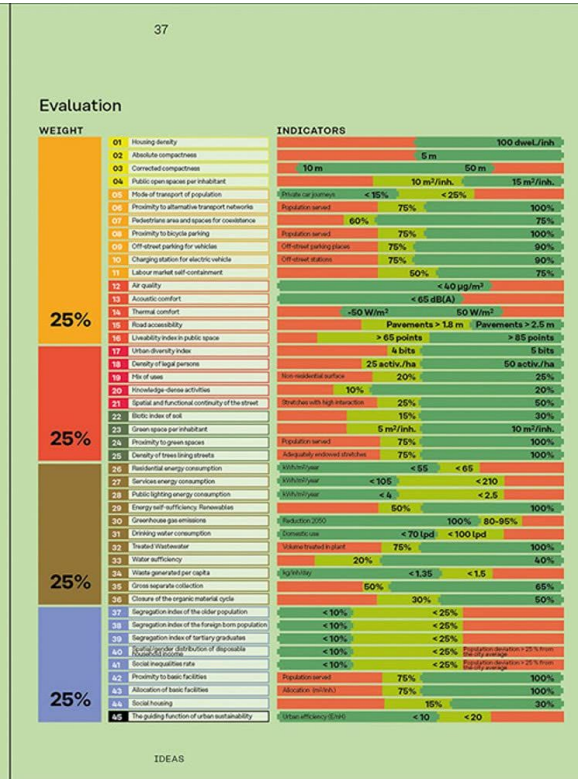
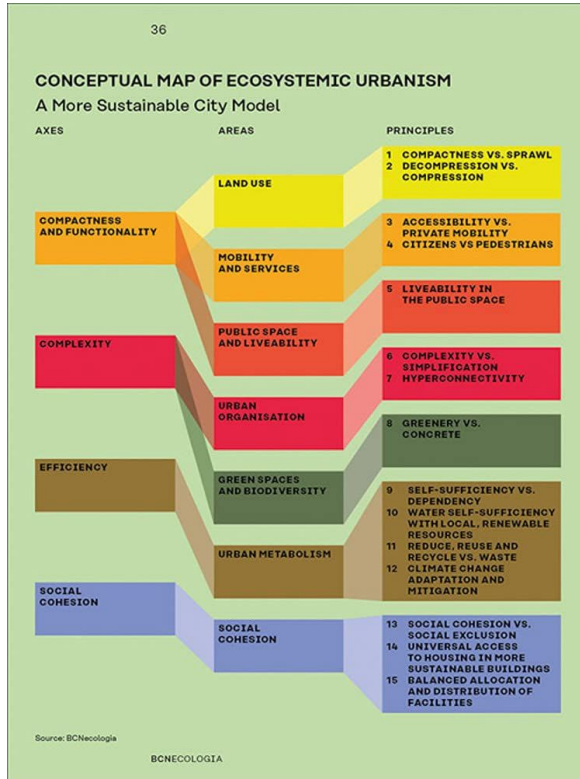

BCNecologia: 20 Years of the Urban Ecology Agency of Barcelona, Jan, 2022.

UNHABITAT, 2022.

PLANOS PARA A CIDADE DE PORTO ALEGRE

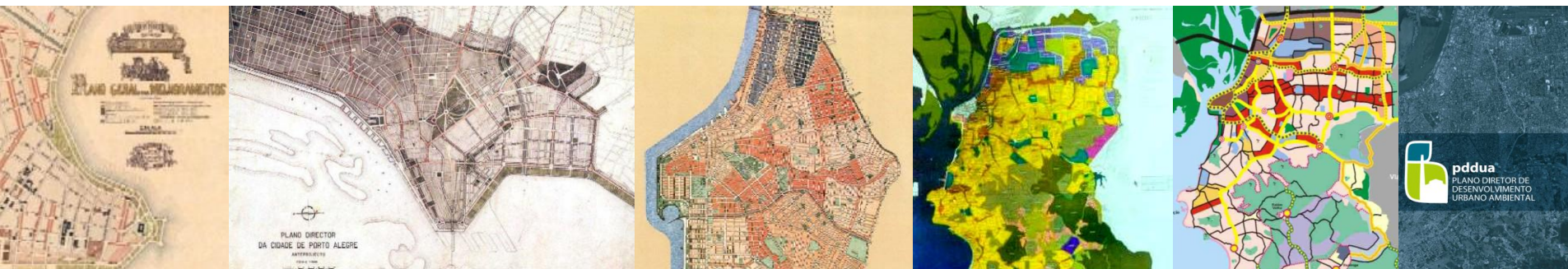
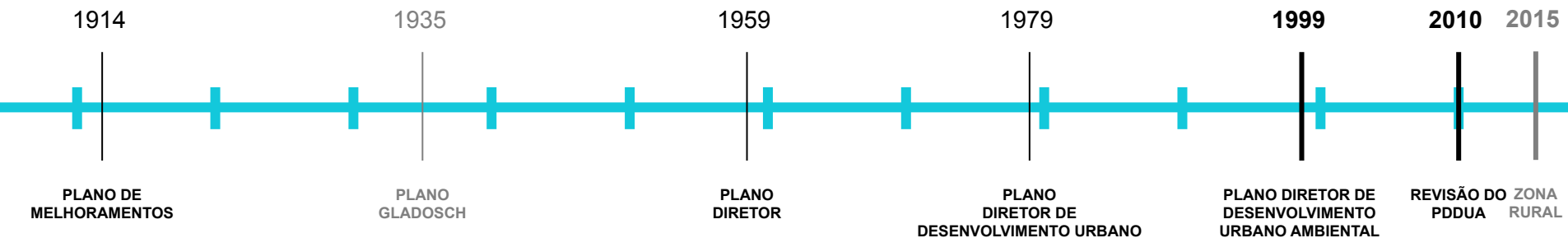

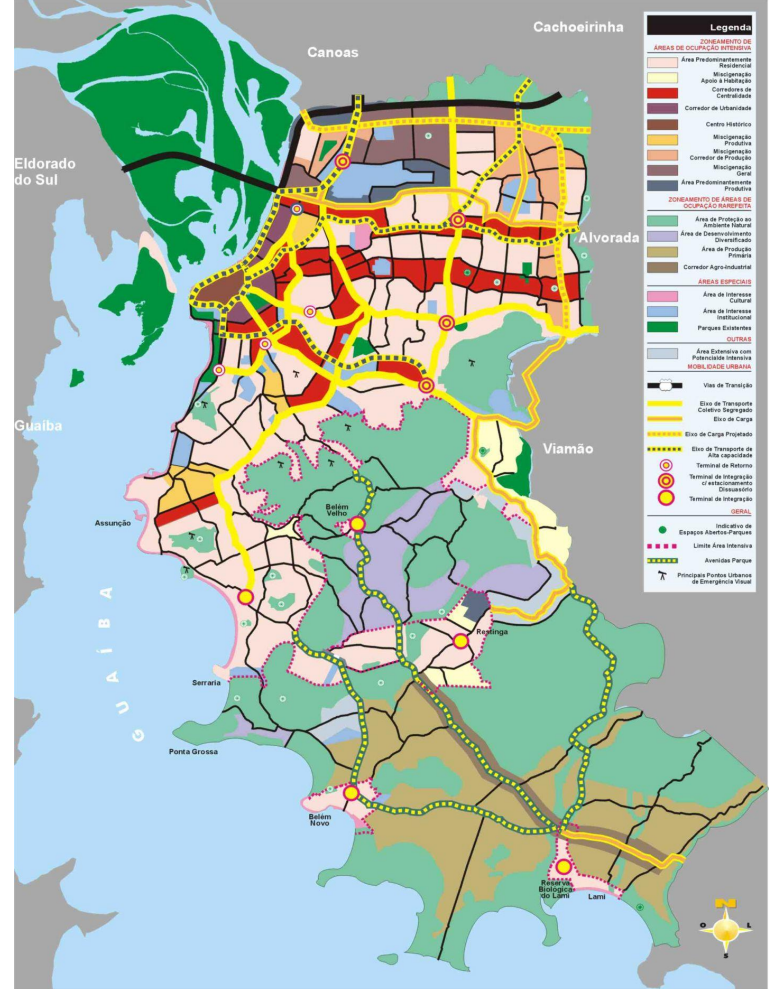
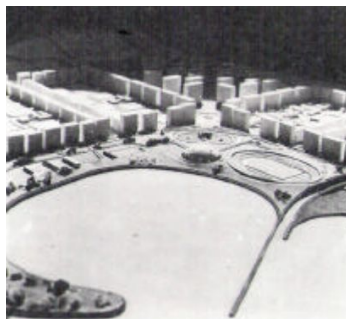
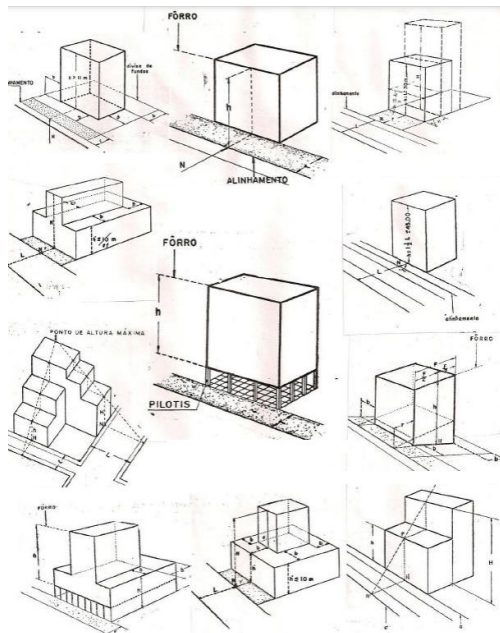
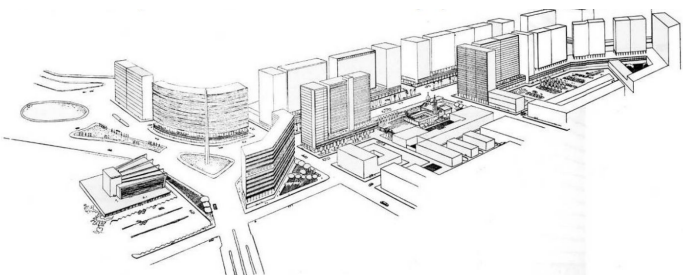
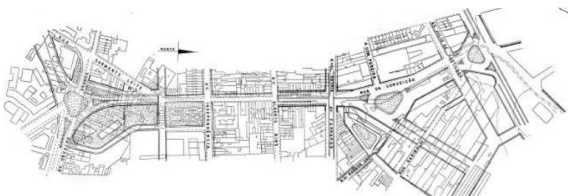

USO DO SOLO PRIVADO

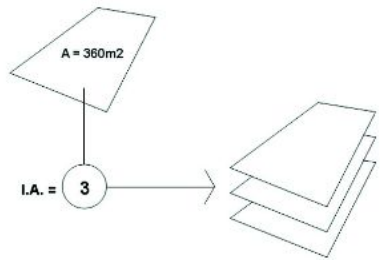
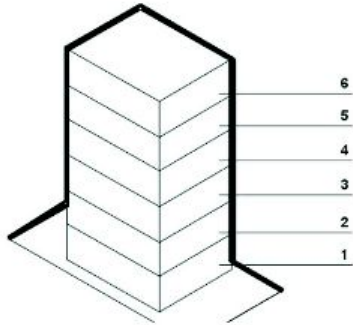
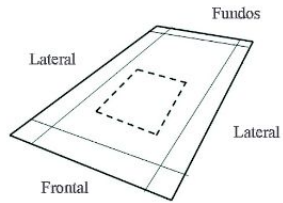
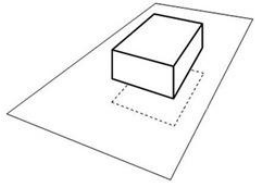



+ JUSTA

+ ACESSÍVEL

+ SAUDÁVEL

+ INTEGRADA

+ DIVERSA

+ INTELIGENTE

+ RESILIENTE

IDENTIDADE



**QUALIDADE
DE VIDA**



PLANO DIRETOR DE PORTO ALEGRE

QUEM AMA A CIDADE
PLANEJA O FUTURO COM ELA

